

# HOXTON 2.0

290mm Rain shower head and arm

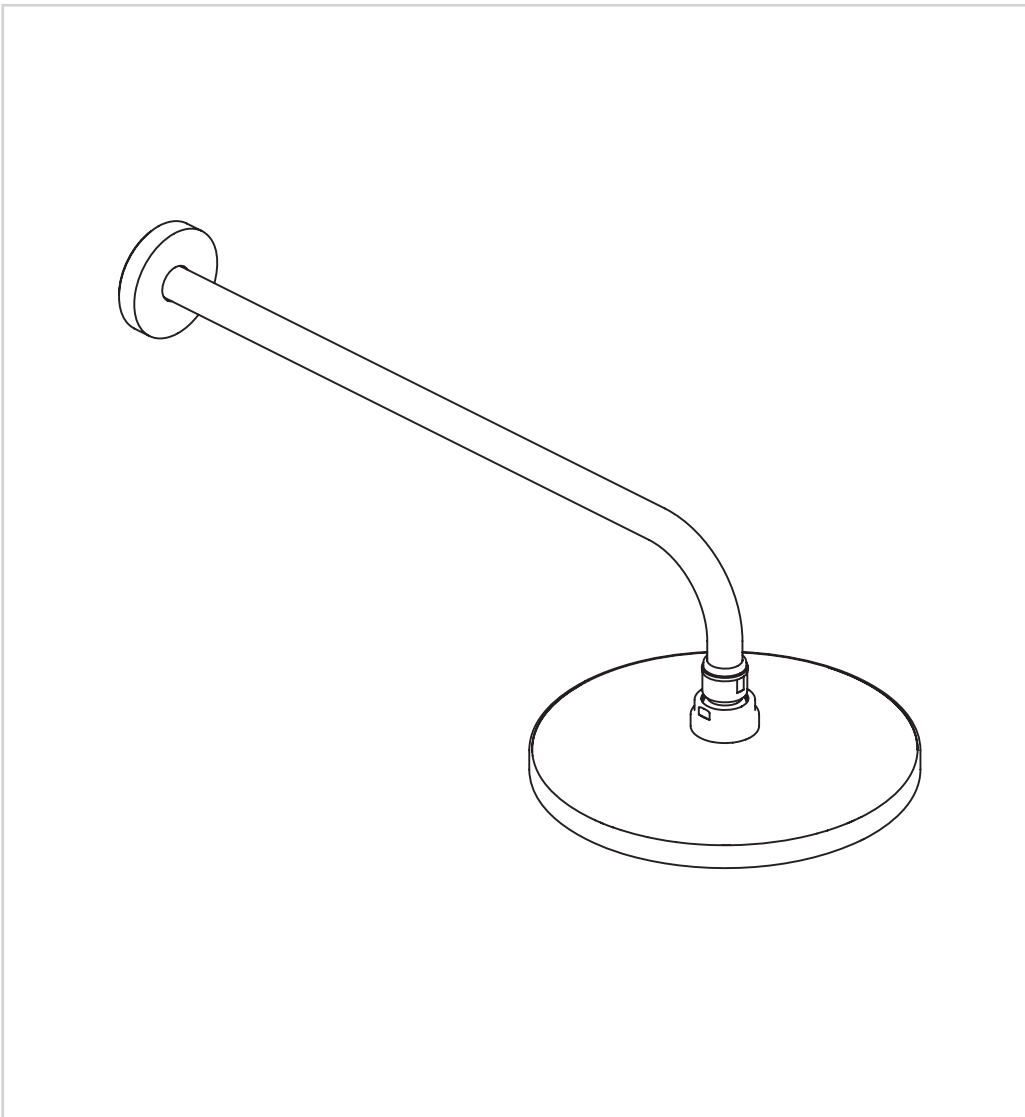

**PRODUCT CODES:**

HOX300



## IMPORTANT INFORMATION BEFORE YOU START

**Please read carefully and keep this information for further reference.**

All products manufactured and supplied by Britton are safe provided they are installed, used correctly and receive regular maintenance in accordance with these instructions. If you are in any doubt about your ability to install this product safely you must employ the services of an experienced qualified plumber.

These fittings need to be installed in accordance with, and meet the requirements of the Water Supply (Water Fittings) Regulations 1999 and Scottish Byelaws 2004.  
Operating pressure range: Minimum 0.5 bar, Maximum 5.0 bar.  
If the mains pressure is over 5 bar, then a flow regulator should be fitted.

Note: Nominally equal (balanced) inlet supply pressures are recommended for optimum performance with mixer taps.

Designed to comply with BS EN 817 for single hole mixers, for water systems of type 2 general technical specifications and to be used within systems designed to BS 6700. BS 6700 recommends the temperature of stored water should never exceed 65°C.

A stored water temperature of 60°C is considered sufficient to meet all normal requirements and will minimise the build up of lime scale in hard water areas. If the fitting is installed at low pressure (tank fed), then the minimum distance from the highest installed position of the outlet to the underside of the cold tank should be at least 2 metres to ensure adequate performance.

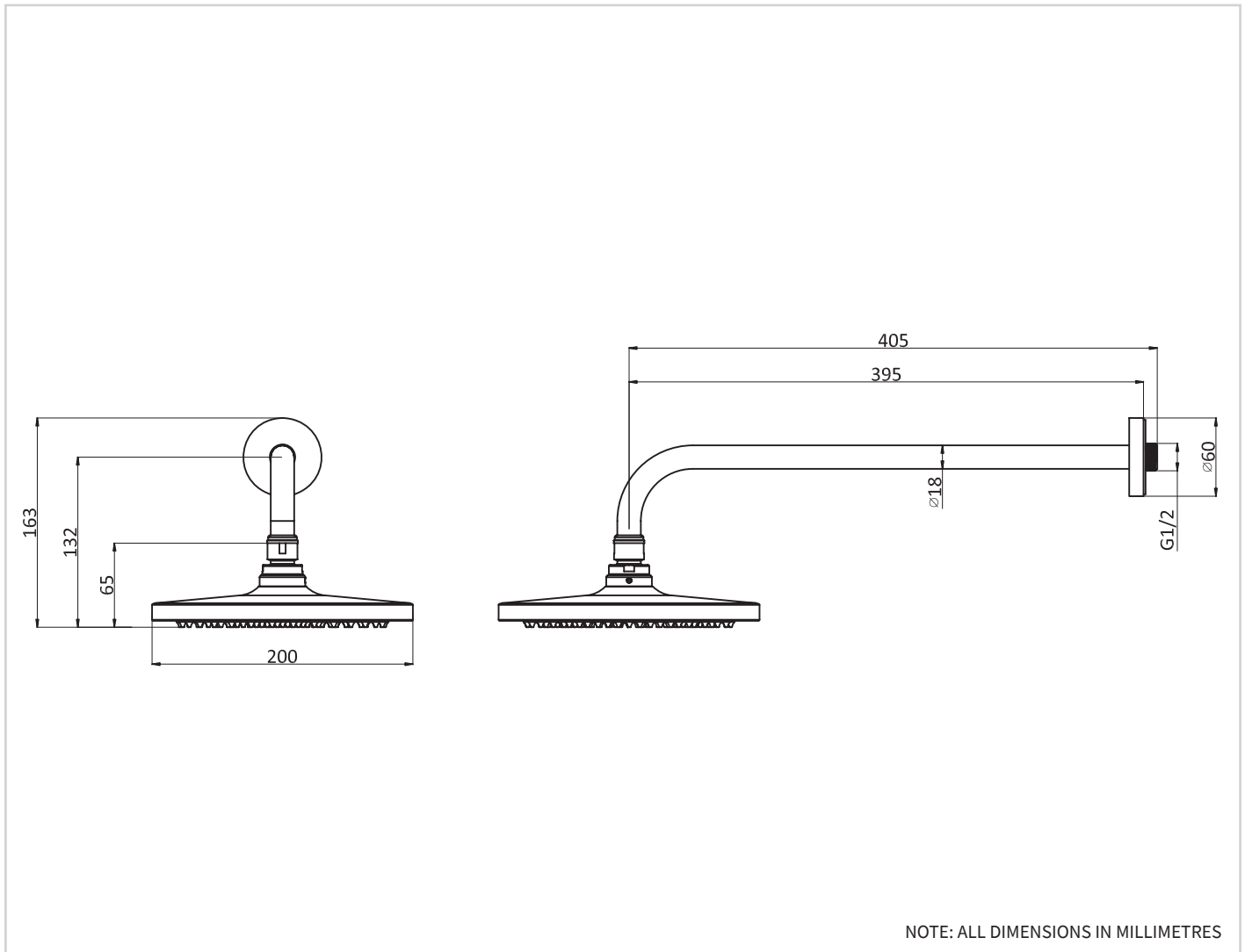
**DIMENSIONS****IMPORTANT INFORMATION**

**Please read carefully and keep this information for further reference.**

The product should be installed in compliance with the Water Regulations.

Please check this product immediately to ensure that it has not been damaged and is complete.

Before installation, please make sure this product is the correct model and you have all the parts required for installation and using.

## BEFORE YOU START

### Important Pre-Installation Notes

Remove all packaging and check the fitting for damage before starting installation.

**Warning:** Before starting any installation please consider the following: before drilling into walls, check that there are no hidden electrical wires, cables or water supply pipes. This can be checked with the aid of an electronic detector.

If power tools are used do not forget to: -

Wear eye protection

Unplug equipment after use

### Important:

Remember to turn off the mains water supply before connecting to any existing pipe work. Fitting isolating valves to the inlet feeds is recommended for ease of maintenance.

**Warning:** Before installing the new fitting it is essential that you thoroughly flush through the pipework in order to remove any remaining swarf, solder, etc. Failure to carry out this procedure could cause problems or damage to the workings of the fitting.

Take care when handling the 'flexible connecting pipes', do not bend, twist or crush them. Only tighten the pipes by hand. Do not crush or kink the shower hose, this could damage the hose and cause leaks.

## INSTALLATION

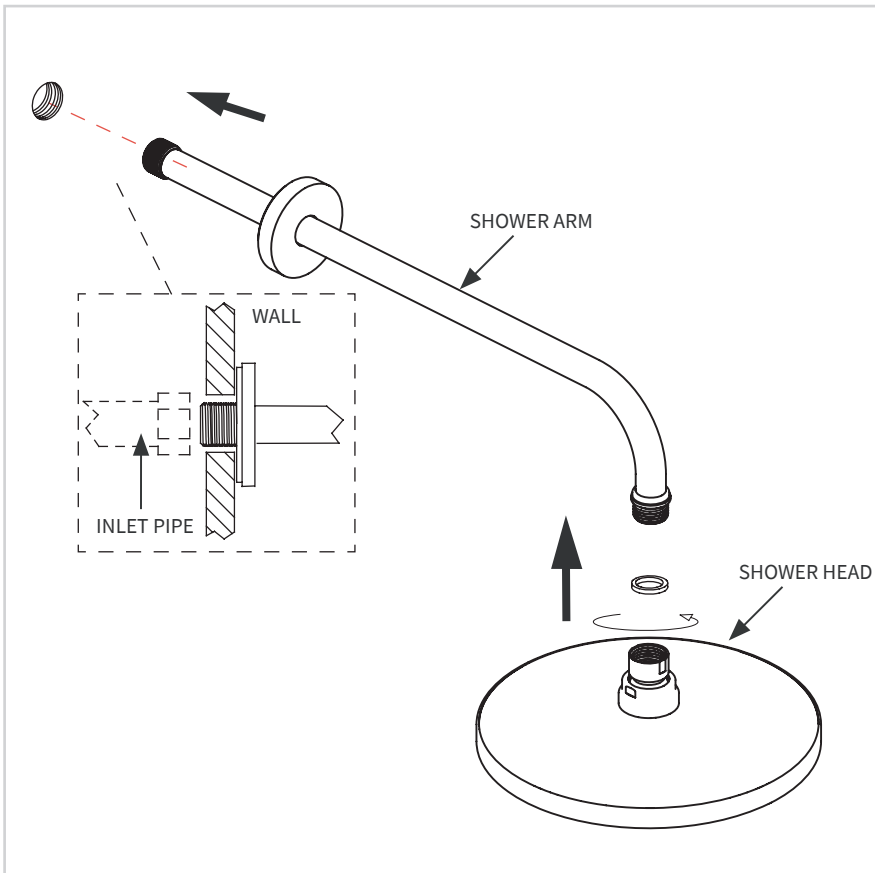

Install the shower arm  
using a suitable thread sealant

## CARE & MAINTENANCE

The material we use in our brassware is very durable, nevertheless care should be taken when cleaning them. They should be cleaned only with warm soapy water followed by rinsing with clean water and drying with a soft cloth. All finishes are vulnerable to acid attack and some strong substances such as household cleaners, disinfectants, denture cleaners, hairdyes, wine making, and photographic chemicals can cause the surface to go black or peel.

Note: Never use abrasive detergents or disinfectants or those containing alcohol, hydrochloric acid or phosphoric acid.